

The Tellun Corporation

TLN-861 Dunsel

User Guide, Rev. 1.0.1

Scott Juskiw
The Tellun Corporation
scott@tellun.com

TLN-861 User Guide
Revision 1.0.1
August 24, 2009

1. Introduction

The TLN-861 Dunsel is a collection of utility circuits for a modular synthesizer. These circuits are all quite simple and can all be found in Jung's Op-Amp cookbook. The Dunsel has two channels, A and B, with one input for each channel and the following independent outputs:

- INV: an inverted version of the input signal.
- NEG: the negative portion of the input signal. For voltages less than zero, the output follows the input. For voltages greater than zero, the output is zero.
- POS: the positive portion of the input signal. For voltages greater than zero, the output follows the input. For voltages less than zero, the output is zero.
- FWR: a full wave rectified version of the input signal: the absolute value of the input signal.
- -5V: the input signal offset down by 5 volts.
- +5V: the input signal offset up by 5 volts.

The Dunsel also provides the following two dependent outputs:

- A+B: the sum of the A and B input signals.
- A-B: the difference of the A and B input signals.

All outputs are capable of driving an oscillator's V/OCT input without any voltage drop across the output stage.

2. Circuit Description

Page 1 of the schematic shows all the circuitry for the A channel. The input signal is buffered by U1a and provides a high input impedance so as not to load down whatever module is driving the input. The output from this buffer (A+) is a non-inverted version of the input and drives a number of the other circuits. The A+ signal is inverted by U1b, to create the A- signal, which also drives a number of the other circuits. U2b provides the inverted A output (INV A). C31 is used to keep spurious oscillations in check when using long cables. Note that R8, the output protection resistor, is included in the feedback loop with R7. This prevents a voltage drop in the output stage when fed to the V/OCT input of an oscillator. This output stage is used many times in the Dunsel.

The A+ signal is fed to U3a where it is half wave rectified and inverted (the A HW+ signal). This signal is then inverted by U3b to provide the positive A output (POS A). U4a performs a similar function on the inverted version of the input signal. The output from this stage (A HW-) is already the correct polarity so it is simply buffered by U4b to provide the negative A output (NEG A). This output stage, using C27, C28, R25, and R26, can be used to drive the V/OCT input of an oscillator without incurring a voltage drop at the output.

The A HW+ and A HW- signals are summed and inverted by U2a to create the full wave rectified signal (FWR A). The offset signals are provided by U5a (A+5) and U5b (A-5) by simply adding an offset to the A- signal and then inverting.

Page 2 of the schematic shows all the circuitry for the B channel which is identical to that used for the A channel.

Page 3 of the schematic shows the circuits for the A+B and A-B outputs. These are simply inverting summers with the appropriate inputs applied; the A-, B+, and B- signals are shown on pages 1 and 2 of the schematic.

3. Construction Tips

Use 1% resistors wherever they are shown in the schematic.

Use coax cable for the jack connections. The TLN-861 can be used with audio signals, so it's a good idea to use coax cable to keep noise out of the circuit. For coax connections between the panel jacks and PCBs, connect the coax shield to ground at both ends of the coax (at the ground lug of the jack and to the square hole on the PCB). When making coax connections between two PCBs, connect the coax shield to ground at one end only. Clip the coax shield from the other end and cover with a piece of heat shrink tubing to prevent any stray strands from coming into contact with anything. At this clipped end, connect only the core (inside) conductor.

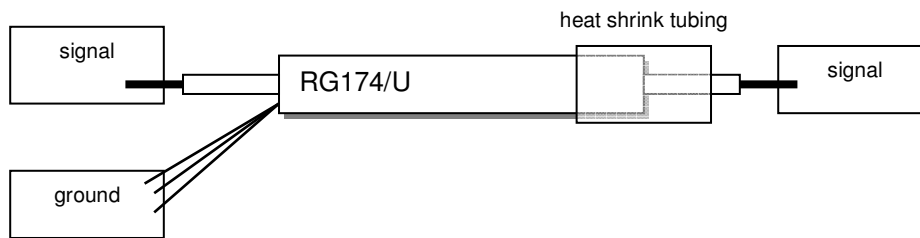

4. Modifications

You can substitute LT1013 op-amps if you want the best DC performance. But LT1013s are slow for audio signals. You can substitute OP275 op-amps if you want the best audio performance, but they have poorer DC performance. I used TL072 op-amps throughout since they are a good compromise between the LT1013 and OP275 and give good results for both DC and audio signals.

5. *Building the Dunsel with MUUBs*

Be sure to check out the construction pictures on the website. Most of what I try to describe below can best be understood just by looking at the pictures.

You'll need four MUUB-4 and three MUUB-2 to build the TLN-861. These boards are designated: 1A, 2A, 3A, 1B, 2B, 3B, and 4. If you look at the pictures on the website, you'll see the seven boards stacked on the Stooge brackets in the following manner:

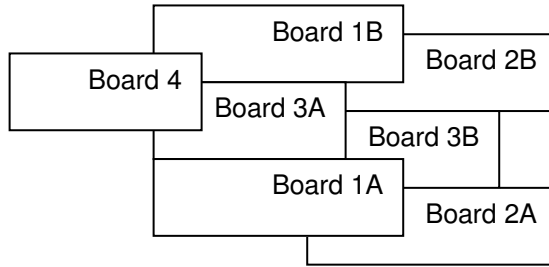

Boards 2B, 3B, and 2A are on the first layer, nearest the Stooge “flat plate modular bracket”. Boards 1B, 3A, and 1A are on the second layer (mounted above the first layer). Board 4 is mounted above board 3A on the third layer.

I built the TLN-861 with Stooge modular brackets and a Stooge compatible 1U wide panel (a prototype panel made from plexiglass). Prepare your panel and Stooge brackets before you do any soldering. Get all the mechanical issues dealt with first. You'll need two of the Stooge “2 jack modular bracket” and one of the Stooge “flat plate modular bracket”.

Once you get the three bracket parts bolted together (use 1/4” #6 screws) and attached to the panel, you should have enough space to mount the first layer of boards (2B, 3B, and 2A) to the bracket using 1/4” spacers and #6 screws. Make sure you leave enough space for the Switchcraft 112A jacks so that they don't interfere with the MUUB-4 boards. Use 3/8” spacers to mount the second layer of boards (1B, 3A, and 1A) above the first layer of boards. Use 3/8” spacers to mount board 4 above board 3A on the third layer. I recommend getting some 1/4” and 3/8” spacers, a wide selection of #6 screws in different lengths (from 1/4” to 1-1/4”), and some extra #6 nuts.

Before beginning the soldering, note the following labeling conventions used in this document for these components.

1. Diodes: banded end is cathode, other end is anode.

5.1. Building Board 1A (MUUB-4)

Use the following table to place components from the TLN-861 schematic onto a MUUB-4 board. For short jumpers, use a scrap resistor lead. For longer jumpers, use a piece of #22 wire. Note that R1 must be placed in an upright position so that it will fit into the holes. Check the website pictures.

<i>Schematic</i>	<i>MUUB-4 Location (board 1A)</i>
R1-10K	CA2, middle and bottom holes, resistor stands upright
R2-470K	RA6
R3-100K	RB1
R4-100K	RB9
R5-49K9	RB13
R6-100K	RD1
R7-100K	RD10
R8-100	RD14
R9-49K9	RD13
R10-100K	RC1
R11-100K	RC2
R12-100K	RC10
R13-100	RC14
R14-33K	RC13
C1-100N	C5 (bypass cap for U1)
C2-100N	C6 (bypass cap for U1)
C3-100N	C3 (bypass cap for U2)
C4-100N	C4 (bypass cap for U2)
C23-22M	C1 (power supply bypass cap)
C25-22M	C2 (power supply bypass cap)
C31-33P	CD3, top and bottom holes
C32-33P	CC3, top and bottom holes
jumper	RA1
jumper	RA5
jumper	RA14
jumper	CA1, middle and bottom holes
jumper	CA3, middle and bottom holes
jumper	RB7
jumper	RB8
jumper	RB14
jumper	CB4 top hole to CB2 middle hole
jumper	CB1, middle and top holes
jumper	TB2, middle to ground hole (at immediate left)
jumper	CC1, middle and bottom holes
jumper	TC2, middle to ground hole (at immediate left)
jumper	CD1, middle and top holes
jumper	TD2, middle to ground hole (at immediate left)

This board contains two electrolytic caps for power supply bypassing, but it does not include the two ferrite beads nor the MTA-156 connector (those items will be installed on board 1B).

Two additional wires are required. Use the following table to make these connections. The wire length and colour (as seen in the website pictures) is also given.

<i>From</i>	<i>To</i>	<i>Length (inches)</i>
RA3 (right hole)	JD1 (right hole)	3 (blue)
RA2 (right hole)	JB1 (right hole)	1.5 (blue)

Note that a number of jumpers are used to create additional outputs for U1a and U1b from unused pads. These additional outputs are needed so that the A+ and A- signals can be fed to other parts of the circuit.

5.2. Building Board 1B (MUUB-4)

Use the following table to place components from the TLN-861 schematic onto a MUUB-4 board. For short jumpers, use a scrap resistor lead. For longer jumpers, use a piece of #22 wire. Note that R37 must be placed in an upright position so that it will fit into the holes. Check the website pictures.

<i>Schematic</i>	<i>MUUB-4 Location (board 1B)</i>
R37-10K	CA2, middle and bottom holes, resistor stands upright
R38-470K	RA6
R39-100K	RB1
R40-100K	RB9
R41-49K9	RB13
R42-100K	RD1
R43-100K	RD10
R44-100	RD14
R45-49K9	RD13
R46-100K	RC1
R47-100K	RC2
R48-100K	RC10
R49-100	RC14
R50-33K	RC13
C11-100N	C5 (bypass cap for U6)
C12-100N	C6 (bypass cap for U6)
C13-100N	C3 (bypass cap for U7)
C14-100N	C4 (bypass cap for U7)
C24-22M	C1 (power supply bypass cap)
C26-22M	C2 (power supply bypass cap)
C36-33P	CD3, top and bottom holes
C37-33P	CC3, top and bottom holes
L1	L1 (ferrite bead)
L2	L2 (ferrite bead)
JP1	MTA-156 power connector
jumper	RA1
jumper	RA5
jumper	RA14
jumper	CA1, middle and bottom holes
jumper	CA3, middle and bottom holes
jumper	RB7
jumper	RB8

jumper	RB14
jumper	CB4 top hole to CB2 middle hole
jumper	CB1, middle and top holes
jumper	TB2, middle to ground hole (at immediate left)
jumper	CC1, middle and bottom holes
jumper	TC2, middle to ground hole (at immediate left)
jumper	CD1, middle and top holes
jumper	TD2, middle to ground hole (at immediate left)

Two additional wires are required. Use the following table to make these connections. The wire length and colour (as seen in the website pictures) is also given

<i>From</i>	<i>To</i>	<i>Length (inches)</i>
RA3 (right hole)	JD1 (right hole)	3 (blue)
RA2 (right hole)	JB1 (right hole)	1.5 (blue)

Note that a number of jumpers are used to create additional outputs for U6a and U6b from unused pads. These additional outputs are needed so that the B+ and B- signals can be fed to other parts of the circuit.

5.3. Building Board 2A (MUUB-4)

Use the following table to place components from the TLN-861 schematic onto a MUUB-4 board. For short jumpers, use a scrap resistor lead. For longer jumpers, use a piece of #22 wire. Check the website pictures.

<i>Schematic</i>	<i>MUUB-4 Location (board 2A)</i>
R15-100K	RA1
R16-100K	RA10
R17-49K9	RA13
R18-100K	RB1
R19-100K	RB10
R20-100	RB14
R21-49K9	RB13
R22-100K	RC1
R23-100K	RC10
R24-49K9	RC13
R25-470	RD14
R26-47K	RD10
D1-4148	RA9 (cathode to left)
D2-4148	RA14 (cathode to right)
D3-4148	RC9 (cathode to left)
D4-4148	RC14 (cathode to right)
C5-100N	C5 (bypass cap for U3)
C6-100N	C6 (bypass cap for U3)
C7-100N	C3 (bypass cap for U4)
C8-100N	C4 (bypass cap for U4)
C27-1N	CD3, top and bottom holes
C28-1N	CD4, top and bottom holes
C33-33P	CB3, top and bottom holes
jumper	CA1, middle and bottom holes

jumper	TA2, middle to ground hole (at immediate left)
jumper	CB1, middle and top holes
jumper	TB2, middle to ground hole (at immediate left)
jumper	CC1, middle and bottom holes
jumper	TC2, middle to ground hole (at immediate left)

Two additional wires are required. Use the following table to make these connections. The wire length and colour (as seen in the website pictures) is also given.

<i>From</i>	<i>To</i>	<i>Length (inches)</i>
CA4 (bottom hole)	JB1 (right hole)	2 (blue)
CC4 (bottom hole)	RD12 (left hole)	2 (blue)

5.4. Building Board 2B (MUUB-4)

Use the following table to place components from the TLN-861 schematic onto a MUUB-4 board. For short jumpers, use a scrap resistor lead. For longer jumpers, use a piece of #22 wire. Check the website pictures.

<i>Schematic</i>	<i>MUUB-4 Location (board 2B)</i>
R51-100K	RA1
R52-100K	RA10
R53-49K9	RA13
R54-100K	RB1
R55-100K	RB10
R56-100	RB14
R57-49K9	RB13
R58-100K	RC1
R59-100K	RC10
R60-49K9	RC13
R61-470	RD14
R62-47K	RD10
D5-4148	RA9 (cathode to left)
D6-4148	RA14 (cathode to right)
D7-4148	RC9 (cathode to left)
D8-4148	RC14 (cathode to right)
C15-100N	C5 (bypass cap for U8)
C16-100N	C6 (bypass cap for U8)
C17-100N	C3 (bypass cap for U9)
C18-100N	C4 (bypass cap for U9)
C29-1N	CD3, top and bottom holes
C30-1N	CD4, top and bottom holes
C38-33P	CB3, top and bottom holes
jumper	CA1, middle and bottom holes
jumper	TA2, middle to ground hole (at immediate left)
jumper	CB1, middle and top holes
jumper	TB2, middle to ground hole (at immediate left)
jumper	CC1, middle and bottom holes
jumper	TC2, middle to ground hole (at immediate left)

Two additional wires are required. Use the following table to make these connections. The wire length and colour (as seen in the website pictures) is also given.

<i>From</i>	<i>To</i>	<i>Length (inches)</i>
CA4 (bottom hole)	JB1 (right hole)	2 (blue)
CC4 (bottom hole)	RD12 (left hole)	2 (blue)

5.5. Building Board 3A (MUUB-2)

Use the following table to place components from the TLN-861 schematic onto a MUUB-2 board. For short jumpers, use a scrap resistor lead. For longer jumpers, use a piece of #22 wire. Check the website pictures.

<i>Schematic</i>	<i>MUUB-2 Location (board 3A)</i>
R27-300K	RA11
R28-100K	RA1
R29-100K	RA10
R30-100	RA14
R31-44K2	RA13
R32-300K	RB11
R33-100K	RB1
R34-100K	RB10
R35-100	RB14
R36-44K2	RB13
C9-100N	C3 (bypass cap for U5)
C10-100N	C4 (bypass cap for U5)
C34-33P	CA3, top and bottom holes
C35-33P	CB3, top and bottom holes
jumper	CA1, middle and bottom holes
jumper	TA1, middle to bottom hole (-)
jumper	TA2, middle to ground hole (at immediate left)
jumper	CB1, middle and top holes
jumper	TB1, middle to bottom hole (+)
jumper	TB2, middle to ground hole (at immediate left)

One additional wire is required on this board. This wire runs from JA2 to JB1 (right holes) but also connects to the right hole of JA1 underneath the PCB. Leave a long enough piece of wire exposed so you can bend it on the underside of the PCB to connect the right holes of JA1 and JA2 together. Later, you will attach another wire to the right hole of JA1 on the topside, so don't fill that hole with solder yet.

<i>From</i>	<i>To</i>	<i>Length (inches)</i>
JA2 (right hole)	JB1 (right hole)	1 (blue)

5.6. Building Board 3B (MUUB-2)

Use the following table to place components from the TLN-861 schematic onto a MUUB-2 board. For short jumpers, use a scrap resistor lead. For longer jumpers, use a piece of #22 wire. Check the website pictures.

<i>Schematic</i>	<i>MUUB-2 Location (board 3B)</i>
R63-300K	RA11
R64-100K	RA1
R65-100K	RA10
R66-100	RA14
R67-44K2	RA13
R68-300K	RB11
R69-100K	RB1
R70-100K	RB10
R71-100	RB14
R72-44K2	RB13
C19-100N	C3 (bypass cap for U10)
C20-100N	C4 (bypass cap for U10)
C39-33P	CA3, top and bottom holes
C40-33P	CB3, top and bottom holes
jumper	CA1, middle and bottom holes
jumper	TA1, middle to bottom hole (-)
jumper	TA2, middle to ground hole (at immediate left)
jumper	CB1, middle and top holes
jumper	TB1, middle to bottom hole (+)
jumper	TB2, middle to ground hole (at immediate left)

One additional wire is required on this board. This wire runs from JA2 to JB1 (right holes) but also connects to the right hole of JA1 underneath the PCB. Leave a long enough piece of wire exposed so you can bend it on the underside of the PCB to connect the right holes of JA1 and JA2 together. Later, you will attach another wire to the right hole of JA1 on the topside, so don't fill that hole with solder yet.

<i>From</i>	<i>To</i>	<i>Length (inches)</i>
JA2 (right hole)	JB1 (right hole)	1 (blue)

5.7. Building Board 4 (MUUB-2)

Use the following table to place components from the TLN-861 schematic onto a MUUB-2 board. For short jumpers, use a scrap resistor lead. For longer jumpers, use a piece of #22 wire. Check the website pictures.

<i>Schematic</i>	<i>MUUB-2 Location (board 4)</i>
R73-100K	RA2
R74-100K	RA1
R75-100K	RA10
R76-100	RA14
R77-33K	RA13
R78-100K	RB1
R79-100K	RB2
R80-100K	RB10
R81-100	RB14
R82-33K	RB13
C21-100N	C3 (bypass cap for U11)
C22-100N	C4 (bypass cap for U11)
C41-33P	CA3, top and bottom holes

C42-33P	CB3, top and bottom holes
jumper	CA1, middle and bottom holes
jumper	TA2, middle to ground hole (at immediate left)
jumper	CB1, middle and top holes
jumper	TB2, middle to ground hole (at immediate left)

One additional wire is required on this board. This wire runs from JA3 to JB1 (right holes) but also connects to the right hole of JA2 underneath the PCB. Leave a long enough piece of wire exposed so you can bend it on the underside of the PCB to connect the right holes of JA2 and JA3 together. Later, you will attach another wire to the right hole of JA2 on the topside, so don't fill that hole with solder yet.

From	To	Length (inches)
JA3 (right hole)	JB1 (right hole)	1 (blue)

5.8. Power Considerations

The seven MUUB boards all require +/-15V and ground. An MTA-156 connector and ferrite beads are installed on board 1B, along with two 22 uF capacitors. Another two 22 uF capacitors are installed on board 1A. Follow the diagram below to daisy chain the three power supply wires between all seven boards. "U" means make the connections on the underside of the board. "T" means make the connections on the topside of the board. Make sure you tap the +/-15V lines from board 1B at the locations marked V+ and V- (three holes each, to the right of L1). On the remaining boards, connect these +/-15V lines to the V+ and V- locations or to the (unused) right holes for L1 and L2. For the ground line, there are lots of unused ground connections on the MUUB boards (e.g. the square holes for JA1-8, JB1-8, JC1-8, JD1-8). Pick ones that are close to the power supply connection.

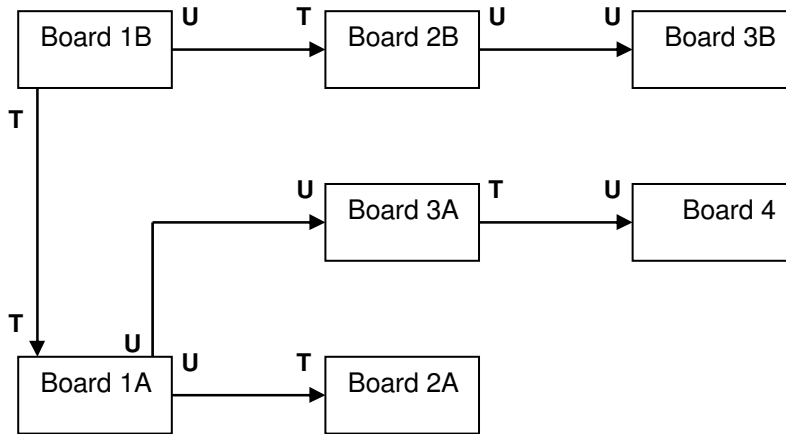

Future versions of the MUUB boards will have larger holes specifically for chaining power supply connections between boards.

5.9. Board to Board Wiring

I recommend using coax cable for all wires going between boards. Connect the coax ground at one side of the cable only (as shown earlier in this document). Connect the wires to the topside or underside of the PCB as indicated in the table below.

<i>From</i>	<i>To</i>	<i>Length (inches)</i>
Board 1A, JA1 underside	Board 2A, JA1 topside	4
Board 1A, JB7 underside	Board 2A, JC1 topside	3
Board 1A, JC2 underside	Board 2A, JA9 topside	4
Board 1A, JC1 underside	Board 2A, JC9 topside	2.5
Board 1A, JB8 topside	Board 3A, JA1 topside	4.5
Board 1B, JA1 underside	Board 2B, JA1 topside	4
Board 1B, JB7 underside	Board 2B, JC1 topside	3
Board 1B, JC2 underside	Board 2B, JA9 topside	4
Board 1B, JC1 underside	Board 2B, JC9 topside	2.5
Board 1B, JB8 underside	Board 3B, JA1 topside	3
Board 1A, JB9 topside	Board 4, JA2 topside	5
Board 1B, JB9 topside	Board 4, JA1 topside	3.5
Board 1B, JA9 topside	Board 4, JB2 topside	5

There should already be a wire in JA2 (right hole) on boards 3A and 3B. Make sure this wire connects to JA1 (right hole) on the underside of each PCB. Similarly, there should already be a wire in JA3 (right hole) on board 4. Make sure this wire connects to JA2 (right hole) on the underside of the PCB.

5.10. Board to Panel Wiring

Use coaxial cable to hook up the jacks. The shield for these wires is connected to ground at both the jack and on the PCB. The square holes on the PCB indicate the ground connections for JA1-9, JB1-9, JC1-9, and JD1-9. All board connections are made on the topside of the PCB.

<i>Panel Item</i>	<i>PCB Connection</i>	<i>Length (inches)</i>
IN A	Board 1A, JA5	4.5
INV A	Board 1A, JD9	4.5
NEG A	Board 2A, JD9	5
POS A	Board 2A, JB9	4.5
FWR A	Board 1A, JC9	5
A – 5	Board 3A, JB9	5
A + 5	Board 3A, JA9	5
IN B	Board 1B, JA5	8
INV B	Board 1B, JD9	6.5
NEG B	Board 2B, JD9	5.5
POS B	Board 2B, JB9	4
FWR B	Board 1B, JC9	5
B – 5	Board 3B, JB9	5.5
B + 5	Board 3B, JA9	5
A – B	Board 4, JB9	6
A + B	Board 4, JA9	5

6. *Testing*

This circuit requires no calibration and is very simple to test. With no input signals applied, the A+5 and B+5 outputs should measure +5V DC, and the A-5 and B-5 outputs should measure -5V DC. All other outputs should measure 0V DC.

Apply a 10Vpp sine wave from an oscillator to the IN A jack and check all the A channel outputs with a scope (make sure nothing is connected to the IN B jack). You should see inverted, negative half, positive half, full wave rectified, and level shifted versions of the input signal at the respective jacks. At the A+B and A-B outputs you should see the input signal unchanged. If you don't have a scope, you can simply listen to the A channel outputs (make sure the oscillator is set to an audible frequency). Or, apply a low frequency oscillator to IN A jack and plug the various outputs into the FM input of an oscillator and listen to that oscillator instead.

Similarly, apply a 10Vpp sine wave from an oscillator to the IN B jack and check all the B channel outputs with a scope (make sure nothing is connected to the IN A jack). You should see inverted, negative half, positive half, full wave rectified, and level shifted versions of the input signal at the respective jacks. At the A+B output you should see the input signal unchanged. At the A-B output you should see an inverted version of the input signal.

If any of the outputs are not working, check the outputs of each of the op-amp sections starting from the input buffer (U1a for channel A) to determine where the signal stops. Most likely there is a wiring error. The Dunsel is a collection of simple op-amp circuits, but there is a fair amount of manual wiring that can result in bad connections or shorted wires. Check your wiring carefully. Check the input signals to each op-amp stage, and check the output from each op-amp.

TLN-861 Parts List

Resistors (82)

Quantity	Description	Part No.	Notes
2	10K	R1, R37	5% or better, Mouser #291-10K
2	470 K	R2, R38	5% or better, Mouser #291-470K
12	100	R8, R13, R20, R30, R35, R44, F49, F56, F66, R71, R76, R81	1%, Mouser #271-100
2	470	R25, R61	1%, Mouser #271-470
4	33 K	R14, R50, R77, R82	1%, Mouser #271-33K
4	44.2 K	R31, R36, R67, R72	1%, Mouser #271-44.2K
2	47 K	R26, R62	1%, Mouser #271-47K
10	49.9 K	R5, R9, R17, R21, R24, R41, R45, R53, R57, R60	1%, Mouser #271-49.9K
40	100 K	R3, R4, R6, R7, R10, R11, R12, R15, R16, R18, R19, R22, R23, R28, R29, R33, R34, R39, R40, R42, R43, R46, R47, R48, R51, R52, R54, R55, R58, R59, R64, R65, R69, R70, R73, R74, R75, R78, R79, R80	1%, Mouser #271-100K
4	300 K	R27, R32, R63, R68	1%, Mouser #271-300K

Capacitors (42)

Quantity	Description	Part No.	Notes
4	1N poly	C27 – C30	Mouser #581-BF014D0102J
22	100N ceramic	C1 – C22	Mouser #147-72-104 Mouser #581-SA105E104M
4	22 uF 35V elec.	C23 – C26	Mouser #140-XRL35V22 (35V)
12	33 pF ceramic	C31 – C42	Mouser #140-50N5-330J

Semiconductors (17)

Quantity	Description	Part No.	Notes
11	TL072 dual op amp	U1 – U11	Allied #735-2727 Mouser #595-TL072CP Digikey #296-1775-5-ND
8	1N4148 diode (can substitute 1N914)	D1 – D8	Allied #263-1538 Mouser #512-1N4148 Digikey #1N4148FS-ND

Miscellaneous

Quantity	Description	Part No.	Notes
16	phone jack Switchcraft 112A	J1 – J16	Allied #932-9391 Mouser #502-112A
11	8 pin DIP socket		for U1 – U11
2	axial ferrite bead	L1, L2	Active #MURJP2141 Mouser #623-2743002112
1	MTA-156 4 pin header	JP1	Mouser #571-6404454 Digikey #A1973-ND

Hardware

<i>Quantity</i>	<i>Description</i>	<i>Notes</i>
1	TLN-861 panel	front panel
4	MUUB-4	printed circuit board
3	MUUB-2	printed circuit board
2	2 jack modular bracket	Stooge bracket
1	flat plate modular bracket	Stooge bracket
	#6-32 screws (1/4", 1/2", 3/4", 1", 1-1/4") spacers (1/4", 3/8") #6-32 nuts #6-32 lock washers	Mouser part numbers: 534-405, 534-407 (spacers) 5721-632-1/4, 5721-632-1/2, 5721-632-3/4 (screws) 5721-632 (nuts), 5721-LWI-6 (lockwashers) (for mounting main circuit boards to Stooge bracket)
1	MTA-156 power cable	Mouser #571-6404264 (connector) Mouser #571-6405514 (dust cover)
4	#8-32 black screw	(for mounting module to cabinet)
	cable ties	
	coax cable (RG174/U)	Mouser #566-8216-100 (100 foot spool)
	hookup wire	
	solder	both organic and no clean



A + B

A - B



A + 5

B + 5



A - 5

B - 5



FWR A

FWR B



POS A

POS B



NEG A

NEG B



INV A

INV B



IN A

IN B



TELLUN CORP
TLN-861 DUNSEL

